

# **Prizelawn® ARC, SPREADER CALIBRATOR**

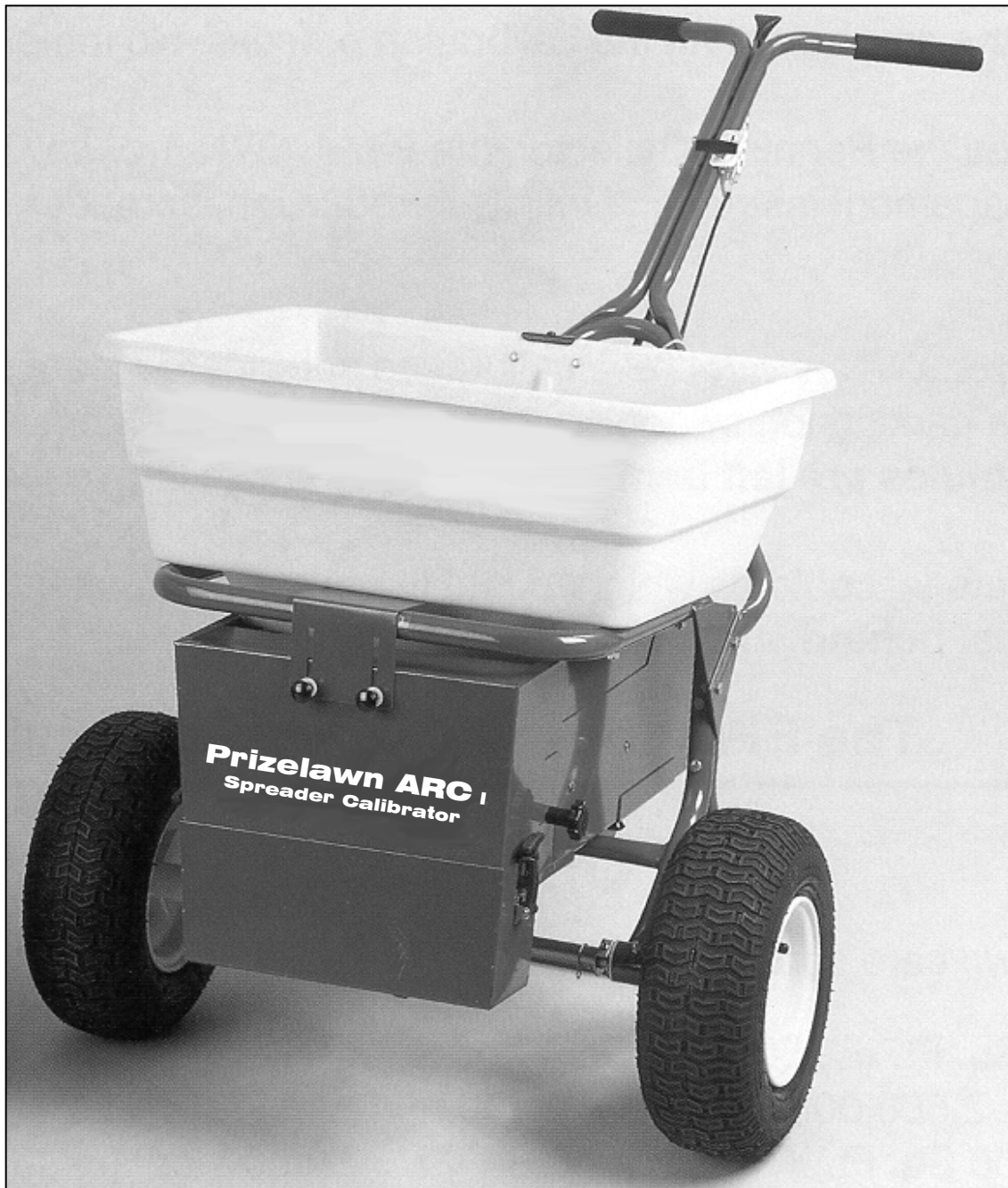

## **OWNERS MANUAL**

The **PrizeLAWN® ARC** i Calibrator, a materials collection box with an easily removable weighing pan, is used during calibration to collect granular products or seed. The Calibrator easily attaches to the spreader and prevents granules or seed from escaping and falling to the ground during the calibration process. The spreader operator walks behind the spreader in the same manner as if fertilizing. The collected material is removed from the collector and then weighed to determine the accuracy of the spreader setting.

**Spreader Calibration Should Be Done Every Time:**

1. A different material is being spread.
2. A different application rate or setting is needed.
3. A change in the humidity or weather conditions.
4. A change in terrain occurs: greens to fairways, level surface to hills.
5. When a spreader hasn't been used in a while.
6. A different operator is using the spreader.
7. The spreader is subject to aging or wear.

The **Prizelawn® ARC** i Calibrator has been designed to fit the following spreaders:

<b>Prizelawn®</b>	<b>LESCO®</b>	<b>ANDERSONS®</b>	<b>SCOTTS®</b>
BF-1,BF-1SS,BF-1HVO,BF-1T,CBR, CBR-II, CBR-III, CBR-IV	Highwheel Mk-II™	ANDEpro2000, AP2000, SR2000	R7X, R8A, SR-1, AP2000, SR2000

## HOW TO DETERMINE SPREADER SETTINGS AND SPREAD WIDTH

Two major factors should be considered when determining correct spreader settings for any product:

1. The **EFFECTIVE PATTERN WIDTH**, or the actual width in which material is applied. Label settings should be used as a guide only and can be effected by numerous factors.
2. The **APPLICATION RATE**, or the actual amount of material applied per 1,000 square feet.

## EFFECTIVE PATTERN WIDTH

A simple visual pattern test can be made by operating the spreader over a non-turf area and evaluating the pattern. A more accurate method is to place a row of common, disposable, aluminum cake pans approximately 1 foot on centers. Set the rate plate at a middle setting and make 3 or 4 passes in the same direction as shown. Pour the material collected from each pan into individual

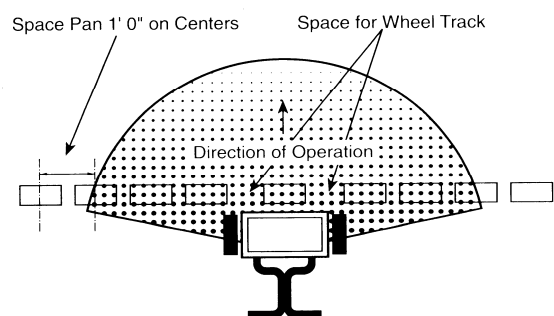

bottles of the same size. Set them side by side in order, and visually inspect their volume. If the pattern is not centered (example: volume in bottle #2 left not equal to bottle #2 right), adjust the pattern as outlined in the OWNER'S MANUAL.

Once the pattern is uniform, the effective pattern width can be determined. The effective pattern width is the distance out from the spreader to a point where the amount of material is 1/2 the average amount in the center pans. This distance is multiplied by 2 to achieve the total effective pattern width. **This test needs to be done only one time for each product.**

## APPLICATION RATE

Determine the product coverage in pounds/ 1,000 sq. ft. by taking the weight of the product and dividing it by the recommended square foot coverage (add three zeroes to the weight of the bag).

**EXAMPLE: Product weight:** 25 lbs.  
**Square foot coverage:** 5,000 sq. ft.  
 25,000 lbs./ 5,000 sq. ft.= 5 lbs/ 1,000 sq. ft.

Select the test site that will allow you to cover 1,000 square feet. If your spreader has an **EFFECTIVE PATTERN WIDTH** of 10 feet, the length will be 100 feet (10' x 100' = 1,000 sq. ft.). Use the chart to determine the number of feet to walk to cover 1,000 square feet.

<u>EFFECTIVE PATTERN WIDTH</u>	<u>DISTANCE</u>
6'	167'
8'	125'
10'	100'
12'	84'
14'	72'

## APPLICATION METHOD

There are two main methods of applying product using a rotary spreader. The **100% OVERLAP METHOD**, and the **PATTERN TO PATTERN METHOD**. Select the method you will be using before calibrating the spreader.

### 100% OVERLAP

This method is based on applying a 50% application rate in one pass in one direction. The next pass is spaced over half the EFFECTIVE PATTERN WIDTH and applying a 50% application rate in the opposite direction as shown.

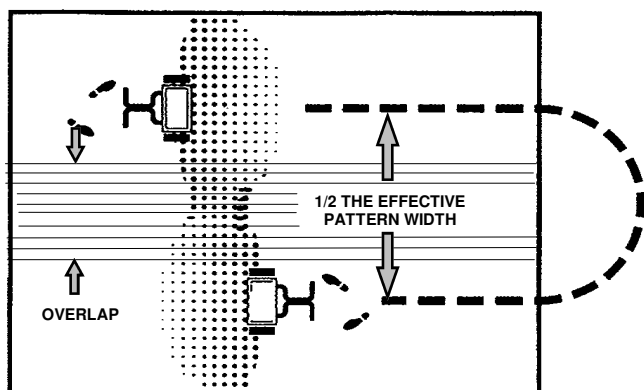

### PATTERN TO PATTERN

This method is based on applying a 100% application rate in one pass over the full EFFECTIVE PATTERN WIDTH and applying a 100% application rate in the opposite direction as shown.

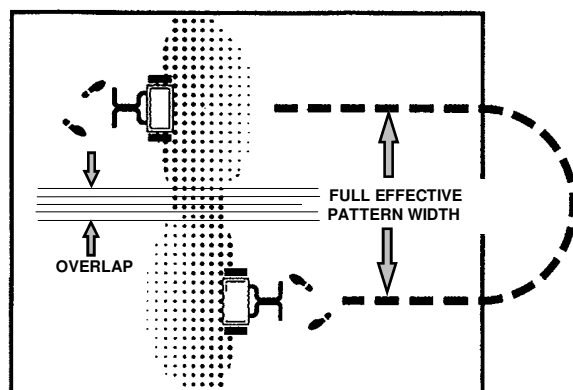

# ASSEMBLY

**1.** Thread the (2) Large Knobs into the hopper sides as shown in Fig. #1 **but do not tighten.** Install the Legs as shown Fig. #1 using the Carriage Bolts, Washers, and Small Knobs. Install the Front Bracket onto the Front Panel Assembly as shown Fig. #2 using (2) Carriage Bolts, (2) Washers, and (2) Small Knobs. (**Prizelawn® CBR ONLY**- loosen the (4) Screws and Nuts and lower the (2) Side Panels. Attached the Baffle Plate to the Front Panel Assembly as shown in Fig. #2 using (2) #10-24 Screws & Nuts.)

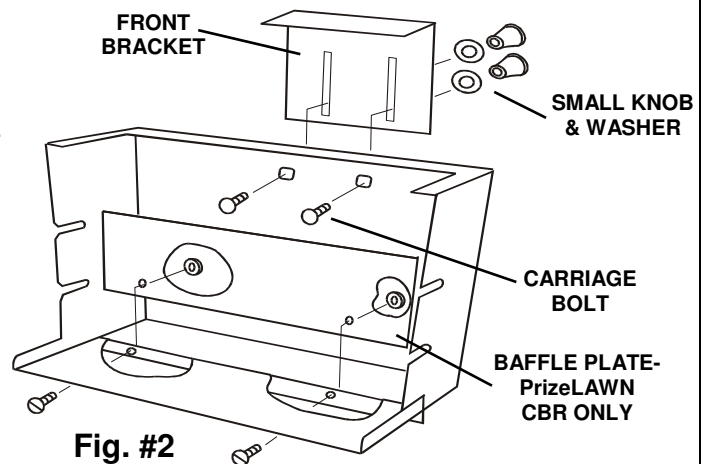
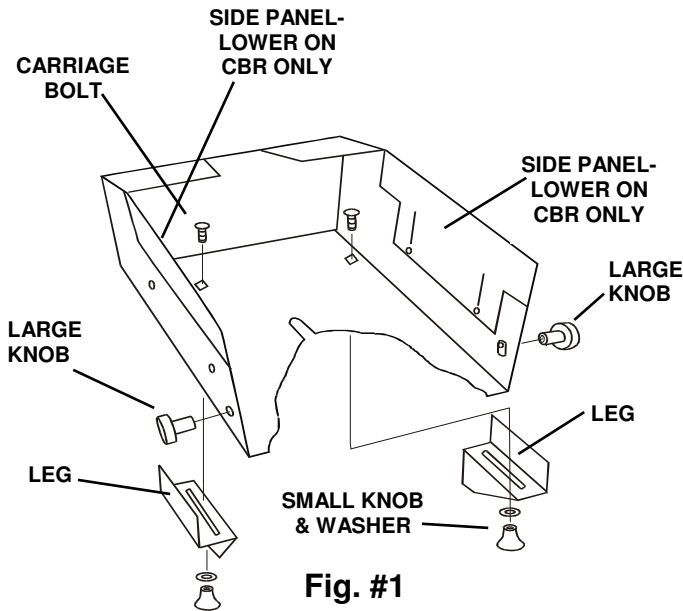

**2.** Remove Gear Cover Halves if you are using a **Prizelawn®**, **Andersons®** or a **Scotts®** spreader. Slide the Hopper Assembly in from the back of the spreader making sure the notch in the bottom slides around the impeller shaft. Slide the Front Panel Assembly in from the front of the spreader making sure the side notches align with the Large Knob as shown in Fig. #3. Attach the Collection Pan Assembly to the Front Panel Assembly as shown using Latches to secure the Pan. (**Prizelawn® CBR ONLY**- use the top notch in Front Panel as shown in

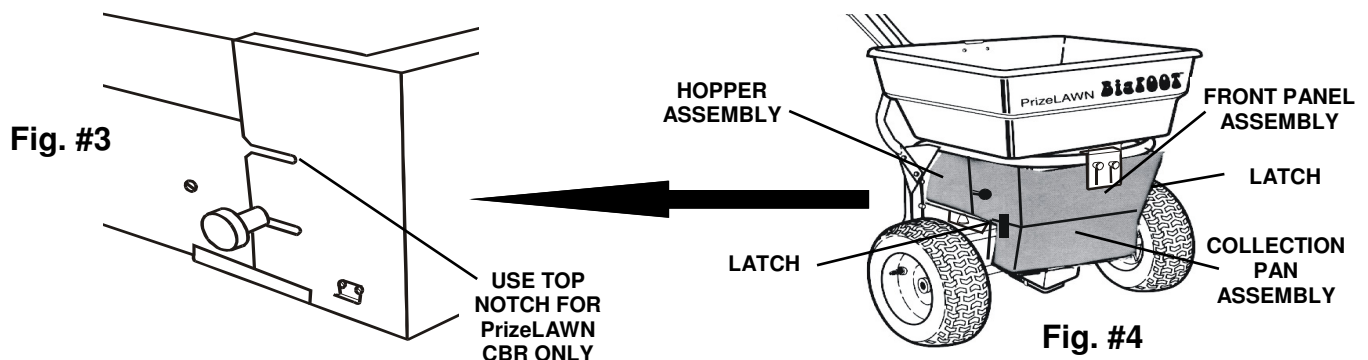

3. Loosen the Small Knobs (2) and adjust the Front Bracket to fit on the front bumper bar. **NOTE:** The Front Bracket may be turned around to better fit your spreader. Loosen the Small Knobs and adjust the Legs as required to lift and level the entire assembly as shown in Fig. #5.

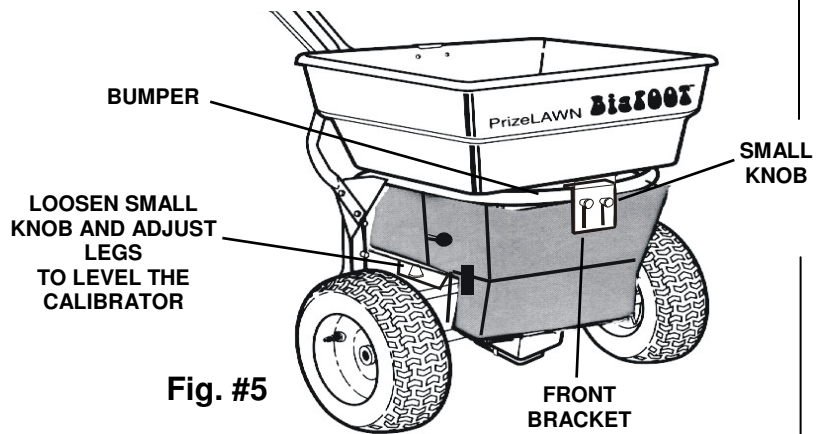

## HOW TO USE & MAINTENANCE

Pour enough material into hopper to allow several passes to be made without running out of product. Use the spreader setting on the bag as a starting point. If no setting is available, use a middle setting.

Walk the distance of the test area as previously determined making sure to open and close the spreader at the exact start point and close at the exact end point. Walking speed should be a constant 2 1/2 MPH. (18 feet in 5 seconds).

When test is completed, place the spreader over a newspaper to catch any overflow of material. Remove pan and weigh material collected and record weight. Adjust the spreader as required and repeat test until application rate is correct.

When finished with test, return leftover material to it's original container. Wash the calibrator thoroughly and wipe dry. Install gear covers if removed.

## WARRANTY

### PSB warrants to Purchaser the following:

1. Product will be free of defects in materials and workmanship for a period of one year from date of purchase.
2. PSB will decide in its reasonable discretion if the part(s)/unit is defective.
3. The spreader or part(s) will be shipped to PSB at the customer expense with a written description of defect to the attention of PSB WARRANTY DEPARTMENT.
4. If the spreader is used for commercial rental the Limited Warranty shall be limited to a period of 90 days.
5. All Unit and part replacement will be performed at the reasonable discretion of PSB.
6. Labor charges are not covered and the unit need not be returned to the dealer for warranty service.
7. Proof of purchase must be supplied to PSB.

PSB's sole obligation under this warranty is limited to repairing or replacing the defective part. Upon replacement of any Product or Product part, the replaced item shall become the property of PSB. If PSB determines that the Product covered by this warranty requires service, PSB shall prepay return shipping charges from PSB. In all other instances, such charges shall be paid by Purchaser. Except for loss or damage caused by PSB's negligence, Purchaser relieves PSB of responsibility for all risks of loss or damage to the Product and its parts during the period the products are in transit to and from PSB.

This warranty does not extend to any Product or parts thereof that have been allowed to corrode, subjected to misuse, neglect, accident, or modification by anyone other than PSB or that have been affixed to any nonstandard accessory attachment or that have been used, stored, installed, maintained or operated in violation of PSB's instructions or standard industry practice. No agent, employee or representative of PSB has any authority to bind PSB to any affirmation, representation or warranty concerning the Product and any affirmation, representation or warranty made by any agent, employee or representative shall not be enforceable by Purchaser.

**THIS WARRANTY EXTENDS ONLY TO THE ORIGINAL PURCHASER AND IS EXPRESSLY IN LIEU OF ANY OTHER EXPRESS OR IMPLIED WARRANTIES, INCLUDING WITHOUT LIMITATION ANY IMPLIED WARRANTY OR MERCHANTABILITY OR FITNESS OR INTENDED USE FOR A PARTICULAR PURPOSE AND OF ANY OTHER OBLIGATION ON THE PART OF PSB.**

**PSB SHALL NOT BE LIABLE FOR ANY INCIDENTAL, SPECIAL OR CONSEQUENTIAL LOSS, DAMAGE OR EXPENSE DIRECTLY OR INDIRECTLY ARISING FROM THE USE OF ANY OF THE PRODUCT INCLUDING, BUT NOT LIMITED TO, DAMAGE OR LOSS OF OTHER PROPERTY OR EQUIPMENT, LOSS OF PROFITS OR REVENUE, COST OF CAPITAL, COST OF PURCHASED OR REPLACEMENT GOODS, OR CLAIMS OF CUSTOMERS OF PURCHASER.**

# PARTS LIST

## ARC CALIBRATOR

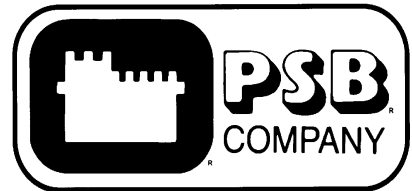
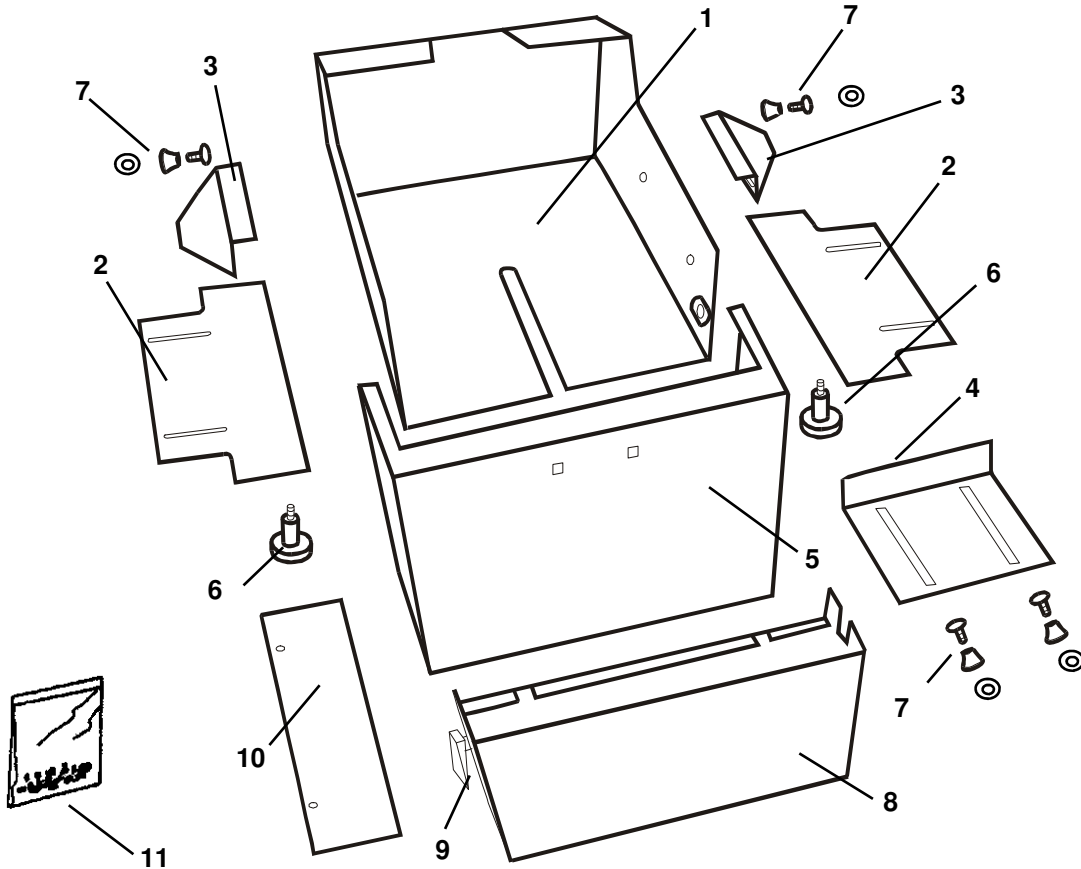

PART OF OUR SERVICE IS PROVIDING REPLACEMENT PARTS. Parts may be obtained through your local distributor. Be sure to give:

1. MODEL NUMBER
2. NAME
3. PART NUMBER
4. NAME OF PART AS SHOWN

IF YOUR LOCAL DISTRIBUTOR CANNOT SUPPLY PARTS, CONTACT:

555 West Goodale Street P.O. Box 1089

Columbus, Ohio 43216-1089

Phone 614-559-2655

Fax 614 221-9398

[www.prizelawnspreaders.com](http://www.prizelawnspreaders.com)

Key No.	Description	Req.	Part No.	Key No.	Description	Req.	Part No.
1	Hopper Assembly	1	15153	7	Small Knob w/ Bolts & Washers	4	14001
2	Side Panel	2	15154-1	8	Collection Pan Assembly	1	15163-1
3	Leg	2	15178	9	Latch Assembly	2	15170
4	Front Bracket	1	15157-1	10	Baffle Plate (CBR Only)	1	15167
5	Front Panel Assembly	1	15159	11	Fastener Package	1	15168-1
6	Large Knob	2	15162				



